



INSTRUCTION BULLETIN

No. 9012963
Machine: T17
Published: 01-2016
Rev. 00

NOTE: DO NOT DISCARD the Parts List from the Instruction Bulletin. Place the Parts List in the appropriate place in the machine manual for future reference. Retaining the Parts List will make it easier to reorder individual parts and will save the cost of ordering an entire kit.

NOTE: Numbers in parenthesis () are reference numbers for parts listed in Bill of Materials.

Installation instructions for **kit number 9020024**

SYNOPSIS:

This kit contains the parts needed to replace the front bumper on T17 scrubbers.
Please follow step-by-step instructions.

SPECIAL TOOLS / CONSIDERATIONS: NONE

(Estimated time to complete: 30 minutes)



PROTECT THE ENVIRONMENT

Please dispose of packaging materials, used machine components such as batteries and fluids in an environmentally safe way according to local waste disposal regulations.

Always remember to recycle.

PREPARATION:

FOR SAFETY: Before leaving or servicing machine, stop on level surface, turn off machine, set parking brake, and remove key.

INSTALLATION:

1. Remove the bumper wheels from the machine. Discard both hitch pins and all six bumper wheels. (Fig. 2)
2. Remove the M8 hex screws securing the right platform bracket and left platform bracket to the bumper. Set the M8 hex screws and flat washers aside. (Fig. 1)
3. Position a jack / jack stands under the front bumper to hold front bumper into place when the M8 hex screws securing it to the machine are removed in the following step. (Fig. 2)
4. Remove the front bumper from the machine. Discard the front bumper and M8 hex screws. (Fig. 2)

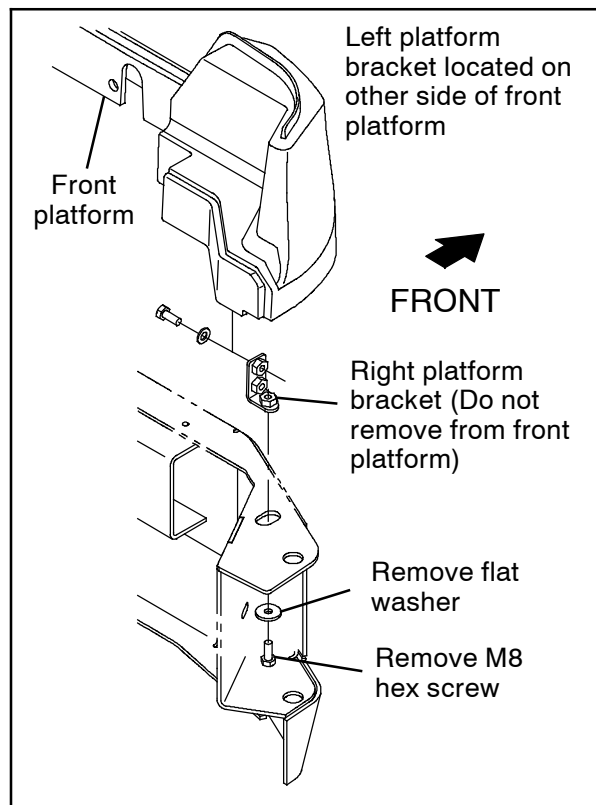

FIG. 1

5. Use a jack / jack stands to hold the new front bumper (1) into place on the front of the machine.
6. Use four M8 SEMS hex screws (2) to secure the front bumper (1) onto the machine. (Fig. 2)
7. Use the saved M8 hex screws / flat washers to secure the right platform bracket and left platform bracket to the bumper. (Fig. 1)
8. Use a hitch pin (4) to install three bumper wheels (3) onto each side of the bumper (1). (Fig. 2)

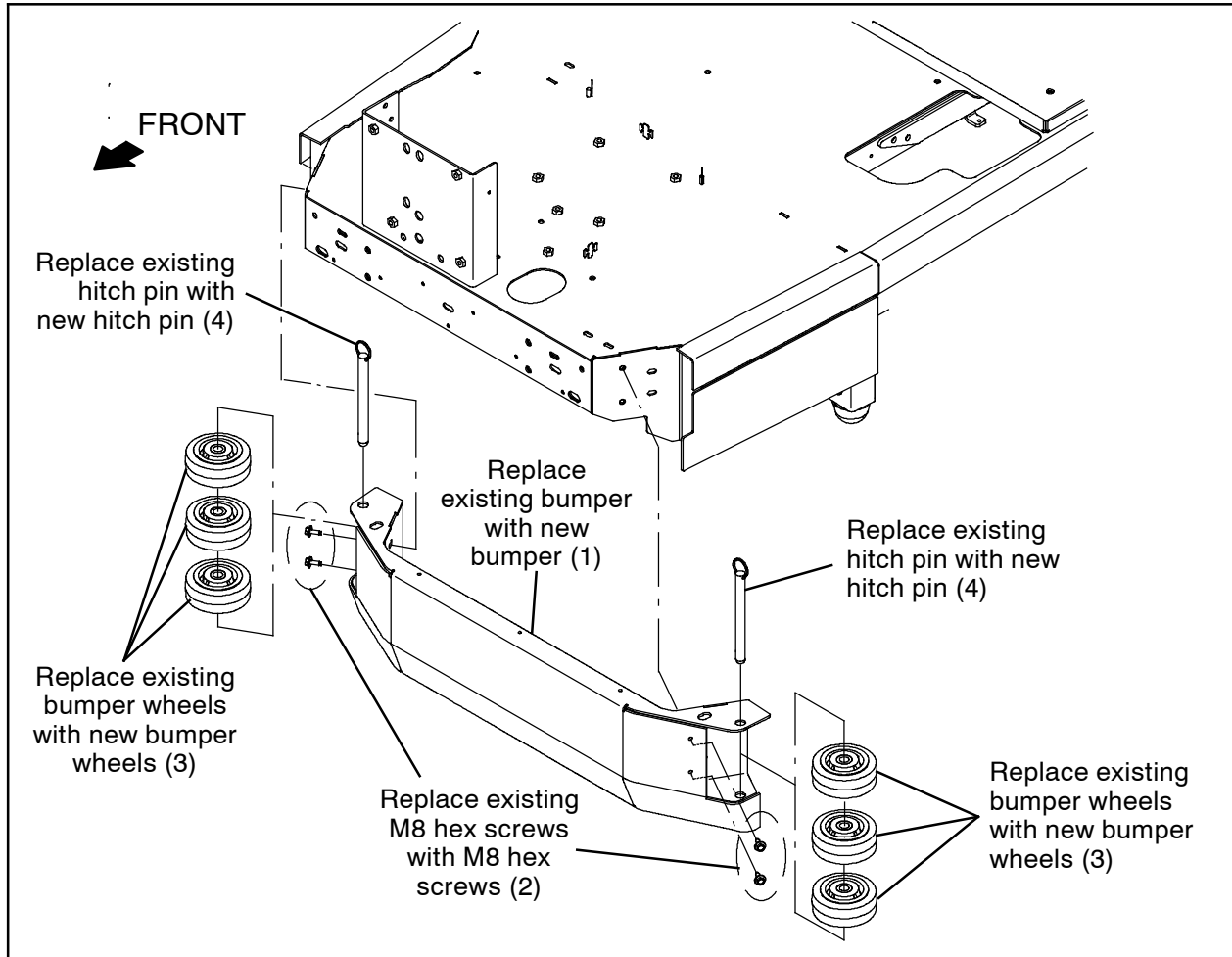

FIG. 2

Bill Of Materials For Bumper Kit, Front, Standard, DI [T17] - 9020024

Ref.	Tennant Part No.	Description	Qty.
1	1205257	Channel Wldt, Bumper	1
2	1037346	Screw, Hex, M8 X 1.25 X 25, 9.8, SEMS	4
3	1052962	Wheel, 05.0D 2.00W 0.75B, Gray, W/ BSHG	6
4	1206367	Pin, Hitch, .750D X 7.00L, PL	2

TENNANT COMPANY
 P. O. Box 1452
 Minneapolis, MN 55440-1452